

Air-Operated Grease Lubricators

Air-Operated Grease Lubricators. Available with 16kg pail.

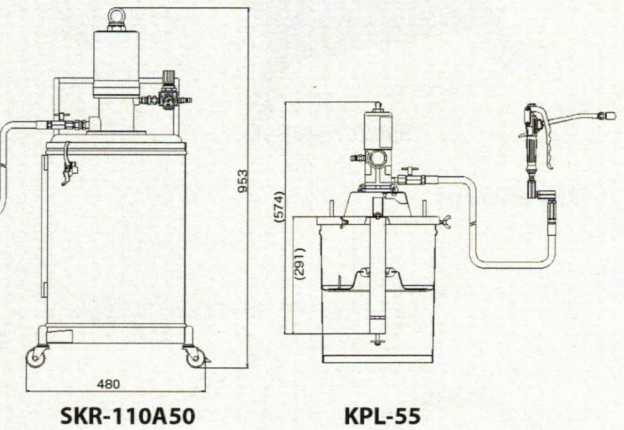

Dimensions

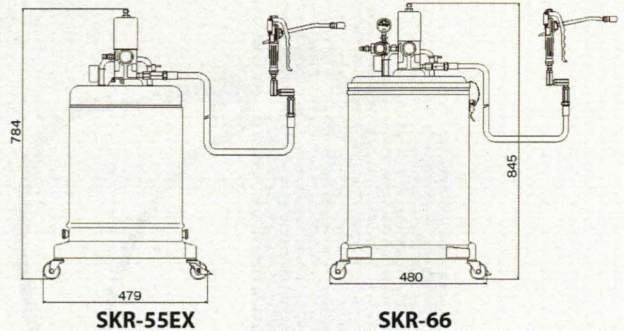

Specifications

Model No.	Model	Container	Pump Ratio	Max Discharge Pressure (MPa)	Max Discharge Volume (g/min)	Max Air Consumption (L/min ANR)	Weight (kg)	Standard Accessories
881190	SKR-55EX	Pail	65 : 1	45.5	320	212	13.5	852498 SKR-55PA Grease Transfer Pump.....1 851985 HPG-G HP Grease Gun.....1 695034 SKR-2.5M Grease Hose 2.5M.....1 800766 Check Valve.....1 680743 PS-20PM Air Coupler Plug.....1
880877	SKR-66	Pail	65 : 1	45.5	320	212	17.6	852764 SKR-66PA Grease Transfer Pump.....1 851985 HPG-G HP Grease Gun.....1 695034 SKR-2.5M Grease Hose 2.5M.....1 800766 Check Valve.....1 802161 Follower Plate.....1 801241 SKR-AR Air Regulator w/ Air Plug.....1
880631	SKR-110A50	Pail	50 : 1	35.0	1200	320	25.0	851779 PD110A50P Grease Transfer Pump.....1 851985 HPG-G HP Grease Gun.....1 695034 SKR-2.5M Grease Hose 2.5M.....1 800431 Check Valve.....1 803481 Follower Plate.....1 802553 AR-110A Air Regulator w/ Air Plug.....1
880873	KPL-55	Pail	65 : 1	45.5	320	212	9.4	852765 KPL-55PA Grease Transfer Pump.....1 851985 HPG-G HP Grease Gun.....1 695034 SKR-2.5M Grease Hose 2.5M.....1 800766 Check Valve.....1 802161 Follower Plate.....1

Optional Accessories

Model No.	Model	Description	Fits Model
802161		Follower Plate	SKR-55, SKR-66, KPL-55
802335	KPL-55C	Caster	KPL-55
695062	SKR-1.5M	Grease Hose 1.5M Max 34.5MPa	SKR-55, SKR-66, SKR-110A50, KPL-55
695050	SKR-2M	Grease Hose 2M Max 34.5MPa	SKR-55, SKR-66, SKR-110A50, KPL-55
695034	SKR-2.5M	Grease Hose 2.5M Max 34.5MPa	SKR-55, SKR-66, SKR-110A50, KPL-55
695049	SKR-3M	Grease Hose 3M Max 34.5MPa	SKR-55, SKR-66, SKR-110A50, KPL-55
695098	SKR-5M	Grease Hose 5M Max 34.5MPa	SKR-55, SKR-66, SKR-110A50, KPL-55
695335	SKR-7M	Grease Hose 7M Max 34.5MPa	SKR-55, SKR-66, SKR-110A50, KPL-55
695099	SKR-10M	Grease Hose 10M Max 34.5MPa	SKR-55, SKR-66, SKR-110A50, KPL-55



802335 KPL-55C



802161 Follower Plate Replacement Hoses

Electric Driven Grease Lubricators

AC100V electric, AC240V electric and DC24V battery driven grease lubricators.
Available with JIS 18L/20L pail.



880899 EPL-100 / 881081 EPL-240

880639 KPL-24

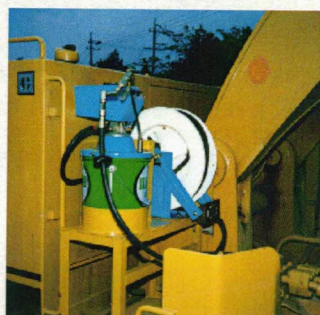

Dimensions

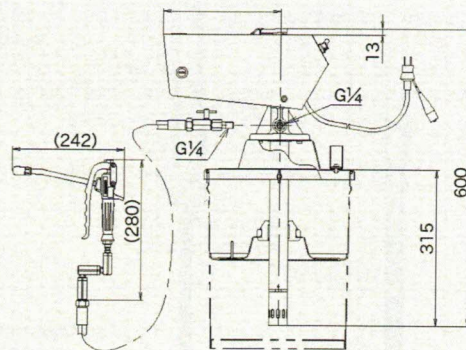

EPL-100 / EPL-240

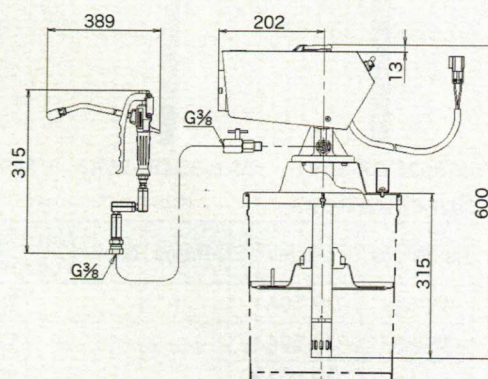

KPL-24

Specifications

Model No.	Model	Usable Container	Power Source	Discharge Volume (g/min)	Max Discharge Pressure (MPa)	Rotating Speed (rpm)	Quake Resistance	Weight (kg)	Standard Accessories
880899	EPL-100	JIS 18L Pail	AC100V 100W 2.0A	200	28	90-145	4G	13.0	851985 HPG-G HP Grease Gun.....1
881081	EPL-240		AC240V 100W 0.83A						695034 SKR-2.5M Grease Hose 2.5M.....1
880639	KPL-24	JIS 18L Pail	DC24V 90W 6.3A	130	28 (30min,rating)	95-108	4G	12.0	803085 Follower Plate.....1 802493 Power Cord Assy.....1 852164 HPG-G13 HP Grease Gun.....1 803085 Follower Plate.....1 685940 Union Adapter.....1 802704 Power Cord Assy.....1

Optional Accessories

Model No.	Model	Description	Fits Model
851003	S-20	Dolly	EPL-100, EPL-240, KPL-24
802335	KPL-55C	Caster	EPL-100, EPL-240, KPL-24
695062	SKR-1.5M	Grease Hose 1.5M Max 34.5MPa	EPL-100, EPL-240
695050	SKR-2M	Grease Hose 2M Max 34.5Pa	EPL-100, EPL-240
695034	SKR-2.5M	Grease Hose 2.5M Max 34.5MPa	EPL-100, EPL-240
695049	SKR-3M	Grease Hose 3M Max 34.5MPa	EPL-100, EPL-240
695098	SKR-5M	Grease Hose 5M Max 34.5MPa	EPL-100, EPL-240
695335	SKR-7M	Grease Hose 7M Max 34.5MPa	EPL-100, EPL-240
695099	SKR-10M	Grease Hose 10M Max 34.5MPa	EPL-100, EPL-240
695303	KPL-24-10M	Grease Hose 10M Max 34.5MPa	KPL-24
802817	KPL-E5M	Extension Power Cord 5M	KPL-24
683239	KPL-BK	Cover	KPL-24
N834488	HR-3C15	Open Hose Reel 15M	KPL-24



N834488 HR-3C15

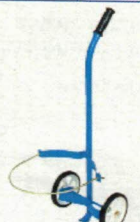

851003 S-20



Replacement Hoses



802817 KPL-E5M



683239 KPL-BK



802335 KPL-55C

Air-Operated Oil Transfer Pumps

Oil Transfer Drum Pumps

Air-operated oil transfer pumps. Drum Bung Adapter is equipped as a standard.



852628 DR-50A1 852633 DR-50A3 880966 DR-90A3

Dimensions

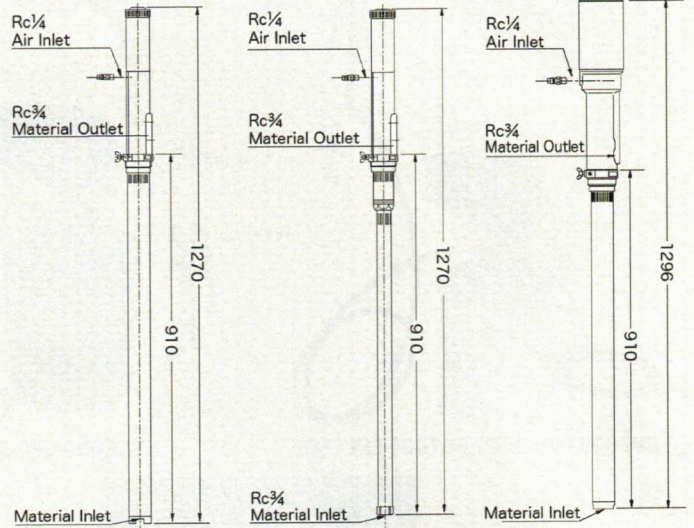

DR-50A1

DR-50A3

DR-90A3

Specifications

Model No.	Model	Pump Ratio	Max Discharge Volume (L/min)	Max Air Consumption (NL/min)	Weight (kg)	Discharge Port
852628	DR-50A1	1 : 1	29.0	460	5.0	Rc3/4"
852633	DR-50A3	3 : 1	12.0	470	5.4	
880966	DR-90A3		22.0	550	7.1	

Oil Transfer Siphon Pumps

Short shank type. Suitable for wall mounting.



852629 SH-50A1 852634 SH-50A3 880967 SH-90A3

Dimensions

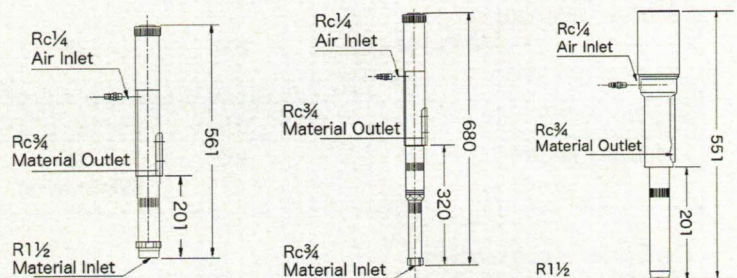

SH-50A1

SH-50A3

SH-90A3

Specifications

Model No.	Model	Pump Ratio	Max Discharge Volume (L/min)	Max Air Consumption (NL/min)	Weight (kg)	Discharge Port
852629	SH-50A1	1 : 1	29.0	460	2.6	Rc3/4"
852634	SH-50A3	3 : 1	12.0	470	3.3	
880967	SH-90A3		22.0	550	4.5	

Pressure Relief Valve & Return Hose

Devices for the purpose of protecting pump, pipe and control valves. When internal pressure of pipe reaches predetermined limit, the Pressure Relief Valve opens and the excess oil is released from the pipe to the drum/tank through the Return Hose.

Model No.	Model	Description
682428	PRV-7	Pressure Relief Valve
695358		Return Hose

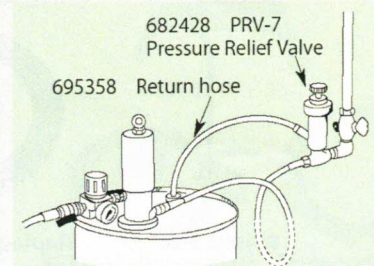

Wall/Floor Mounting Sets

Wall/Floor mounting sets for Oil Transfer Siphon Pumps.

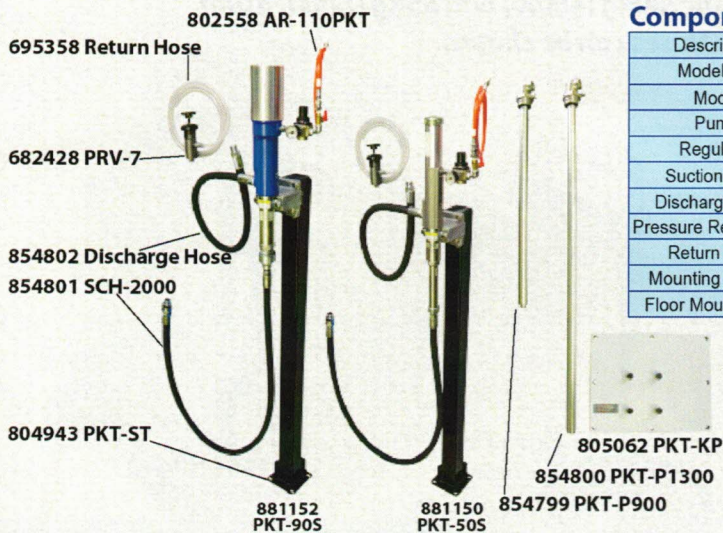

Components

Description	Wall Mounting Set		Floor Mounting Set	
	Model No.	Model	Model No.	Model
Model No.	881149	881151	881150	881152
Model	PKT-50	PKT-90	PKT-50S	PKT-90S
Pump	852634 SH-50A3	880967 SH-90A3	852634 SH-50A3	880967 SH-90A3
Regulator	802558 AR-110PKT (with R1/4 × 1.5m Hose)			
Suction Hose	854801 SCH-2000			
Discharge Hose	854802 Discharge Hose (R3/4 × 1.5M)			
Pressure Relief Valve	682428 PRV-7			
Return Hose	695358 Return Hose			
Mounting Bracket	800400 MTB-SH			
Floor Mount Stand	-----		804943 PKT-ST	

Optional Accessories

Model No.	Model	Description	Remark
854799	PKT-P900	Suction Pipe for 200L Drum	L=906mm
854800	PKT-P1300	Suction Pipe for Tank	L=1,300mm
805062	PKT-KP	Wall Mounting Panel	Fits to PKT-50,PKT-90

Dolly Sets

Mobile Unit equipped with type 110 and 90 air-operated oil pump. *Drum is not included



881182 LDS-110D2 881183 LDS-110R2 881184 LDS-90D2

Components

Model No.	Model	Pump	Air Regulator	Control Valve	Dolly	Hose Reel
881182	LDS-110D2	851754 DR-110A5	805199	801428 LBM-G	686832 LDS-CT2	-----
881183	LDS-110R2	851754 DR-110A5		686845 GR-4G15		
881184	LDS-90D2	880966 DR-90A3	686858 ODV-30D	-----		

Liquid Level Alarms

When the liquid level reaches a predetermined limit, this totally pneumatic liquid level sensor automatically stop the pumps and it blows the whistle instead.

It can be mounted to 200L drum directly by 3/4" bung adapter.

When using with Pressure Relief Valve (PRV-7) and Return Hose, please use RL-SA Return Hose Adapter.

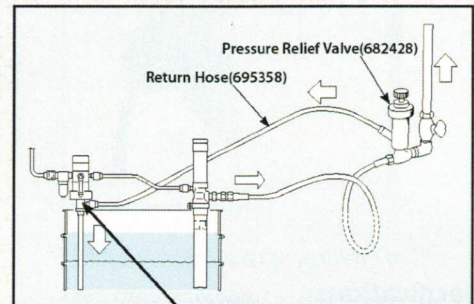
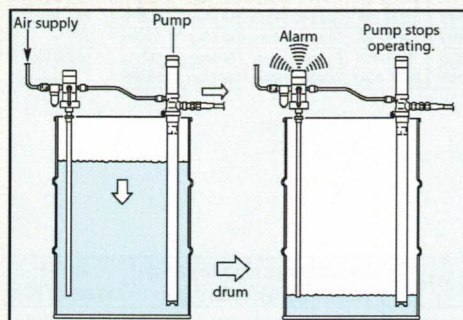
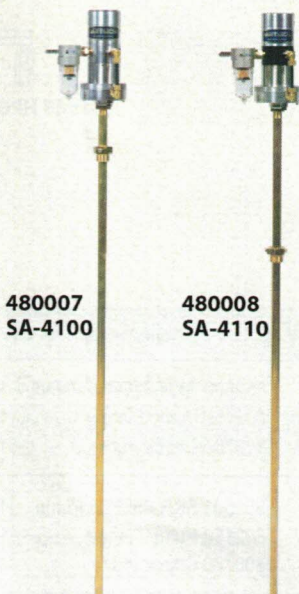

802781 RL-SA Return Hose Adapter

Specifications

Model No.	Model	Application	Air Pressure (MPa)	Max Output Air Flow (L/min ANR)	Viscosity Limit	Weight (kg)	Standard Accessories
480007	SA-4100	Lower limit detection	0.25-0.7	1000	2.5Pa-s (2,500cps)	2.2	680743 PM-20PM Air Coupler
480008	SA-4110	Upper limit detection					

Air-Operated Grease Transfer Pumps

Grease Transfer Drum Pumps

Air-operated Drum Cover and follower plate kit for 180kg (400lb) and 55kg (120lb) drum.
Grease Gun and wide variety of length of Grease Hoses can be chosen.

Dimensions

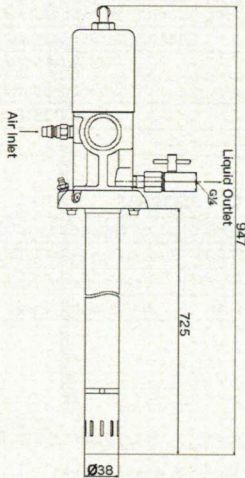
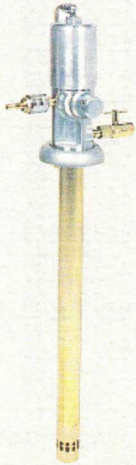

880846 SKR-725A55
Drum Pump for 55kg(120lb) Drum

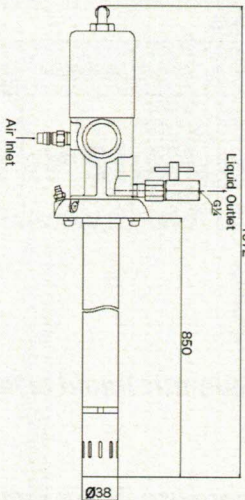
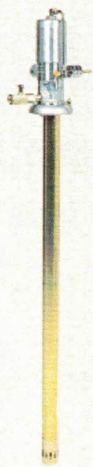

880847 SKR-850A55
Drum Pump for 180kg(400lb) Drum

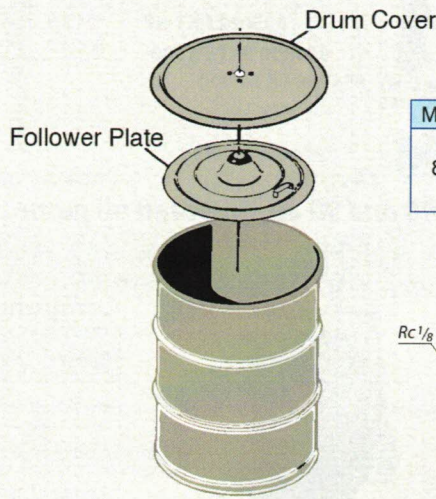
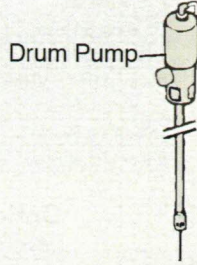

Grease Hoses

Model No.	Model	Description
695062	SKR-1.5M	Grease Hose 1.5M Max 34.5MPa
695050	SKR-2M	Grease Hose 2M Max 34.5MPa
695034	SKR-2.5M	Grease Hose 2.5M Max 34.5MPa
695049	SKR-3M	Grease Hose 3M Max 34.5MPa
695098	SKR-5M	Grease Hose 5M Max 34.5MPa
695335	SKR-7M	Grease Hose 7M Max 34.5MPa
695099	SKR-10M	Grease Hose 10M Max 34.5MPa

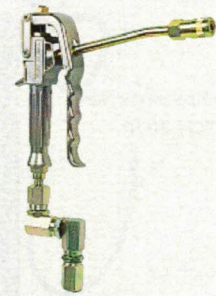

851985 HPG-G
HP Grease Gun

Model No.	Model	Description	Components
851985	HPG-G	HP Grease Gun	852165 Gun Body.....1 800547 CNP-2.....1 802910 HPG-J Swivel-1

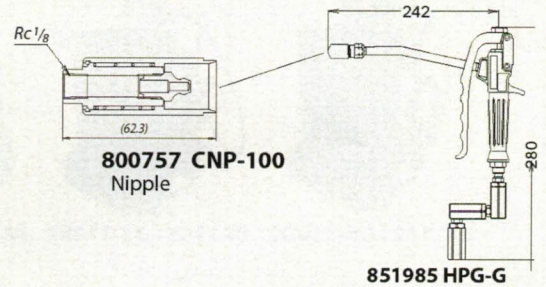

800757 CNP-100
Nipple

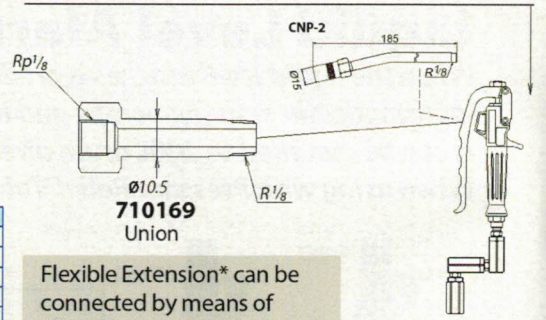

710169
Union

Flexible Extension* can be connected by means of Nipple or Union

*See page 3 for detail

Specifications

Model No.	Model	Shank Length (mm)	Suitable Container	Pump Ratio	Max Discharge Pressure (MPa)	Max Discharge Volume (g/min)	Max Air Consumption (NL/min)	Weight (kg)	Components
880846	SKR-725A55	725	55kg (120Lbs)	65:1	45.5	320	212	5.8	852500 SKR-725P55 Pump.....1 802159 Pump Flange.....1 800766 Check Valve.....1
880847	SKR-850A55	850	180kg (400Lbs)	65:1	45.5	320	212	6.8	852501 SKR-850P55 Pump.....1 802159 Pump Flange.....1 800766 Check Valve.....1

Compact Reel YR Series

Air Hose Reels

Compact and light-weight air hose reels with durable and flexible 1/4" x 10M hose.



686608
YR-2A10

686609
YR-2A10S

Dimensions

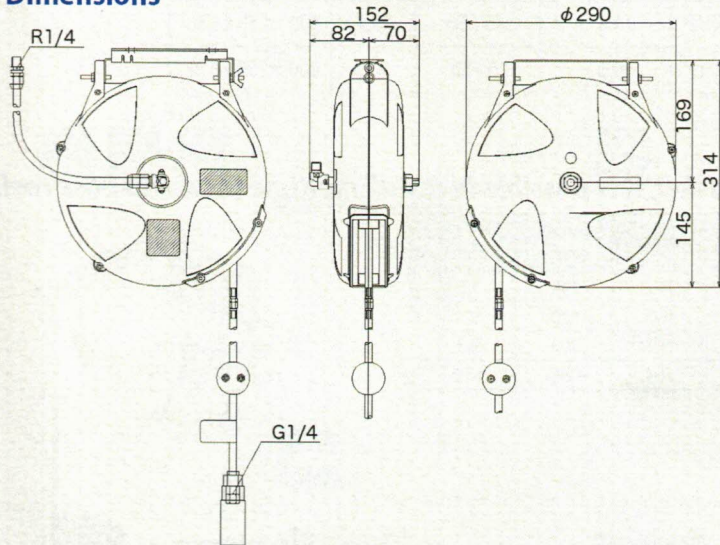

Installation

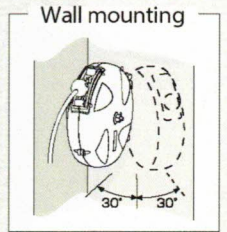
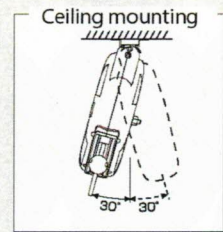

Swing function is equipped as a standard

Easy Coupling

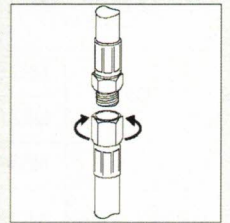
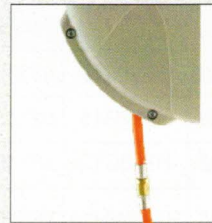

Delivery hose can be changed easily by "Easy Coupling"

Spark Resistant Hose

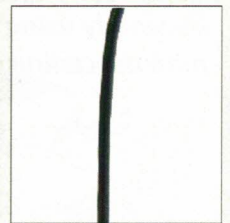
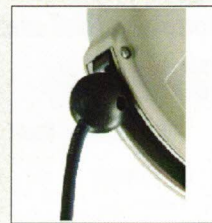

YR-2A10S is equipped with spark resistant hose

Specifications

Model No.	Model	Delivery Hose				Max Pressure (MPa)	Inlet Hose		Weight (kg)
		I.D. (mm)	Length (M)	Connection	Material		Length (m)	Connection	
686608	YR-2A10	6.5	10.0	G1/4"	Urethane	1.4	0.8	R1/4"	3.5
686609	YR-2A10S				Urethane (Spark Resistant)				

Hose Reel HR Series

Hose Reels

Open type hose reel with durable engineering plastic reel drum.

Angle of delivery hose outlet can be adjusted depending of place of installation.



N834288
HR-3G10

N831989
HR-4G15

N834488
HR-3C15

N834388
HR-3WH15

686877
YSR-4A15T

686878
YSR-4W15T

Specifications

Media	Model No.	Model	I.D. x Length x Connection		Max Pressure (MPa)	Temp Range (°C)	Weight (kg)	Dimensions (mm) H x W x Ø	Mounting Dimension (mm)
			Delivery Hose	Inlet Hose					
Oil	N834288	HR-3G10	3/8"x10MxG3/8"	1/2"x1MxG1/2"	7.5	-40 - 100	12.1	560 x 223 x 426	125 x 157 x 4-Ø13
	N831989	HR-4G15	1/2"x15MxG1/2"						
Grease	N834488	HR-3C15	3/8"x15MxG3/8"	3/8"x1MxG3/8"	35.0	16.9	560 x 228 x 426		
HP Hot Water	N834388	HR-3WH15	3/8"x15MxG3/8"	3/8"x1MxG3/8"	25.0MPa (50°C) 10.0MPa (150°C)	13.8	560 x 227 x 426		

Specifications

Media	Model No.	Model	I.D. x Length x Connection		Max Pressure (MPa)	Temp Range (°C)	Weight (kg)	Dimensions (mm) H x W x Ø
			Delivery Hose	Inlet Hose				
Air	686877	YSR-4A15T	1/2"x15MxR1/2"	1/2"x1MxR1/2"	1.4	-5 - 50	18.7	600 x 255 x 538
Water	686878	YSR-4W15T	1/2"x15MxR1/2"	1/2"x1MxR1/2"	0.5	0 - 50	19.5	600 x 255 x 538

Mounting Brackets

By simply using Mounting Rail and Mounting Bracket, it is possible to install multiple HR series hose reels onto the ceiling easily.

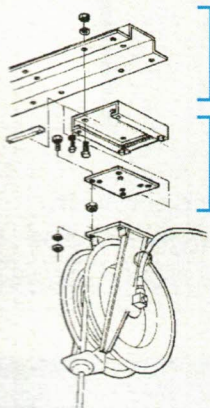

Mounting Rail

No. of Reel	Model No.	Model	Length (mm)	Weight (mm)
1	704439	R-1	140	1.5
2	704440	R-2	520	5.3
3	704441	R-3	900	9.2
4	704442	R-4	1280	13.0

801951 RK-S Mounting Bracket

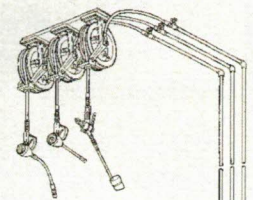
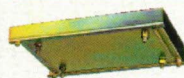

Swing Brackets increase range of use at the wall-mounted.



N372407 RK-W
Wall mounting swing bracket (SPCC)



N372408 RK-WSUS
Wall mounting swing bracket (SUS)

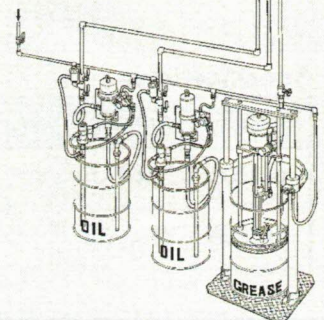

Control Valves

Wide variety of control valves available

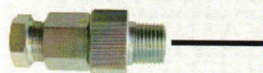

804553 OIL-SJ

Swivel joint
Rc3/8 and Rc1/2 x R1/2

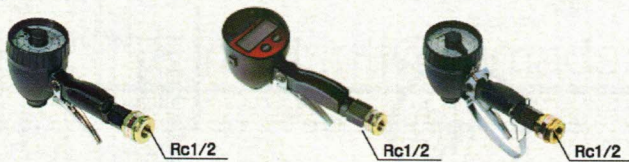

801428 LBM-G

Lube mechanical meter

802765 LBM-D

Digital meter

801429 LBM-60

802238 LBM-30

802237 LBM-16

Mechanical preset meter



686773 LBM-P19

Digital batch meter



805160 NDN-FS-3

Non-drip flexible pipe extension with swivel nozzle



805159 NDN-F-3

Non-drip flexible pipe extension



805161 NDN-H-3

Non-drip flexible hose extension

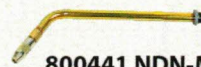

800441 NDN-M

Non-drip steel extension 60° angled head



804570 NDN-PS

Non-drip steel extension with swivel nozzle



801152 NDN-P

Non-drip steel extension



705387 NDZ-P

Steel extension



800440 NDN-G

Non-drip steel extension right-angled head



801204 NDN-L

Non-drip steel extension L-shape pipe



686857 ODV-30

Oil control gun

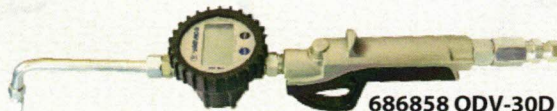

686858 ODV-30D

Electric oil control gun



800680 DN-L

Non-drip steel extension L type



800730 DN-T

Non-drip steel extension T type

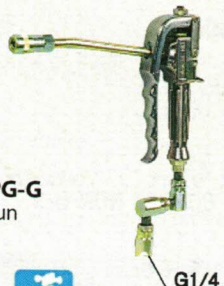

851985 HPG-G

HP Grease Gun



686654 YCL-18LED

AC 100V-7W LED pendant light



686653 YCL-18

AC 100V-13W fluorescent pendant light



SJ-S Swivel Joint

- N431510 1/2x3/8 Brass
- N431610 1/2x1/2 Brass
- N431710 1/2x3/4 Brass
- N431810 1/2x3/8 SUS
- N431910 1/2x1/2 SUS
- N432010 1/2x3/4 SUS



N400210

SGS-W
Water gun SUS



N400310

SGS-R
High Temperature Water gun SUS



N400110

SGB-B
Water gun Brass



803926 WG-20

Water spray gun

Dimensions

N834488 HR-3C15

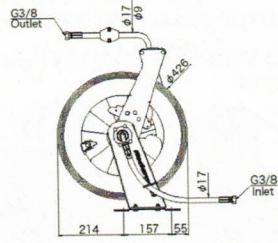

N834388 HR-3WH15

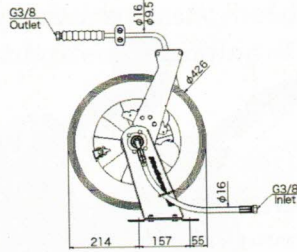

686877 YSR-4A15T

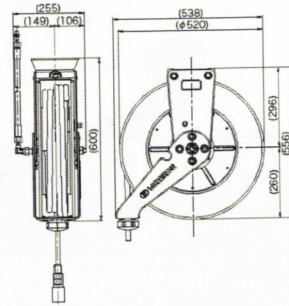

N834288 HR-3G10

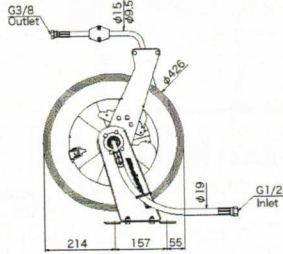

N831989 HR-4G15

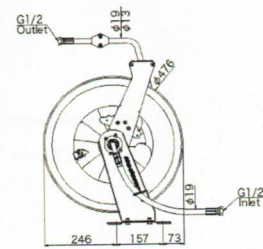

686878 YSR-4W15T

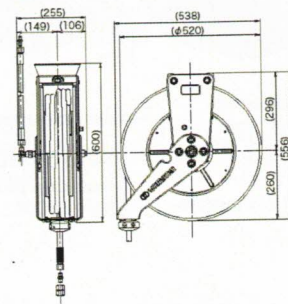

801237 LBM-16
802238 LBM-30, 801429 LBM-60

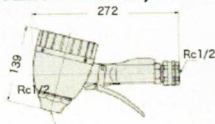

686773 LBM-P19

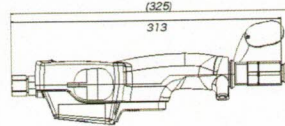

686857 ODV-30

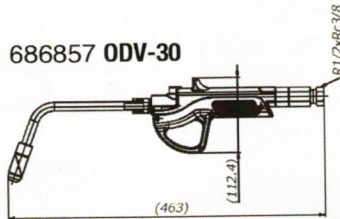

686858 ODV-30D

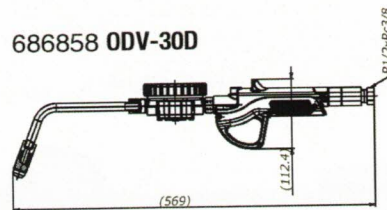

851985 HPG-G

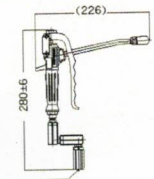

800440 NDN-G

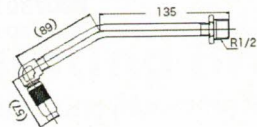

804570 NDN-PS

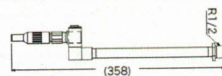

801152 NDN-P

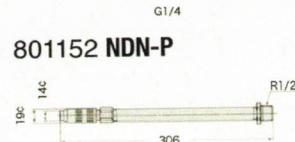

800680 DN-L

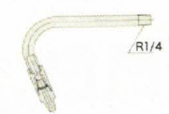

705387 NOZ-P



800441 NDN-M

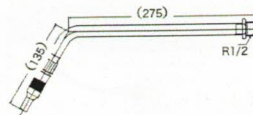

801204 NDN-L

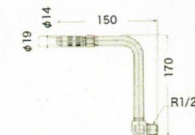

800730 DN-T

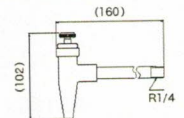

805159 NDN-F-3

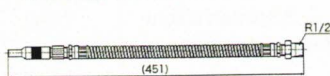

805160 NDN-FS-3

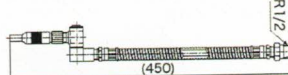

805161 NDN-H-3

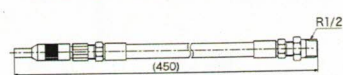

N400110 SGB-B

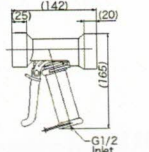

N400210 SGS-W

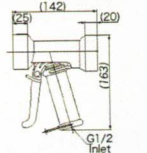

N400310 SGS-R

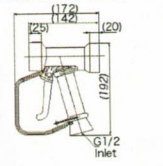

803926 WG-20

